

## OVERHEAD CROSSINGS - PIPELINE

DRAWING NUMBER	SHT.	DRAWING TITLE	DWG REV.	BOM REV.
C-24-23.01	1	PIPELINES CROSSING SASKATCHEWAN BORDERS	<b>B</b>	-
C-24-23.01	2	PIPELINES CROSSING SASKATCHEWAN BORDERS	<b>C</b>	-
C-24-23.02	1	APPLICATION REQUIREMENTS	<b>0</b>	-
C-24-23.02	2	APPLICATION REQUIREMENTS	<b>0</b>	-

### *SaskPower* - DISTRIBUTION STANDARDS

APPROVAL	DESIGN CHK	DRN. <b>ARU</b>	<b>INDEX</b>	
<b>L. MOEN</b>	<b>A. UHREN</b>	CHKD.		
		<b>2017-05-03</b>		
DATE OF ISSUE: 2017/05/03		DRAWING NO: <b>C-24-23-INDEX</b>	<b>SHEET 1 of 1</b>	<b>REV. C</b>

I. OVERHEAD POWER LINES PROPOSED TO CROSS EXISTING PIPELINES WHICH CROSS SASKATCHEWAN BORDERS AND ARE UNDER THE JURISDICTION OF THE NATIONAL ENERGY BOARD.

ALL FIELD STAFF INVOLVED WITH PIPELINE CROSSINGS SHOULD HAVE A COPY OF M8-21. THIS DRAWING SHOWS PIPELINES WHICH CROSS PROVINCIAL BORDERS AND THEIR LOCATIONS THROUGHOUT THE PROVINCE. (A COPY OF M8-21 CAN BE OBTAINED FROM T & D DRAFTING AND ENGINEERING RECORDS, HEAD OFFICE.)

REGION OR DEPT. TO CONTACT PIPELINE CO. DIRECTLY WITH NOTIFICATION OF 72 HRS. (\* SOME PIPELINE CO. REQUIRE DOCUMENTATION, THEREFORE EARLY CONTACT IS RECOMMENDED). OVERHEAD CROSSING OF OVER 50 kV, OVERHEAD CROSSING OF ANY VOLTAGE WITH ANY SASKPOWER POLES, PYLONS, ANCHORS, GUYS, OR ANY FACILITY PLACED WITHIN PIPELINE COMPANIES RIGHT-OF-WAY, MUST PROVIDE REQUESTED INFORMATION AS LISTED BELOW. THE FIELD OFFICE MUST GO THROUGH THIS DEPARTMENT.

THE REQUEST TO THE T & D SUPPORT SERVICES DEPARTMENT SHOULD CONTAIN:

- ALL DIMENSIONS IN METRES TO ONE DECIMAL.
- SUBPROJECT NUMBER.
- CROSSING IN RELATION TO NEAREST ROAD ALLOWANCE CENTRE LINE OR SECTION LINE.
- INDICATE VOLTAGE AND CONDUCTOR SIZE.
- CROSSING NUMBER, IF EXISTING, LOCATION, AND NORTH SIGN CORRECT.
- ATTACH STAKING SHEET TO FIELD CHECK SHEET.
- AS BUILTS TO BE SUBMITTED AT EARLIEST POSSIBLE TIME TO CONTRACT ADMINISTRATION DEPARTMENT, HEAD OFFICE.
- TIME AND DATE OF THE PROPOSED CONSTRUCTION.

OVERHEAD PIPELINES CROSSINGS THAT ARE BELOW 50 kV AND DO NOT ENCR OACH UPON THE PIPELINES RIGHT-OF-WAY MAY BE CONSTRUCTED OVER THE PIPELINE WITHOUT PRIOR APPROVAL IF IT IS DESIGNED AND CONSTRUCTED IN ACCORDANCE WITH THE "PIPELINE OVERHEAD CROSSING ORDER". THE PIPELINE COMPANY(S) MUST HAVE 72-HOURS NOTIFICATION PRIOR TO CONSTRUCTION. (\* SOME PIPELINE CO. REQUIRE DOCUMENTATION THEREFORE

EARLY CONTACT IS RECOMMENDED). THE VERTICAL DISTANCE BETWEEN THE LOWEST WIRE OF AN OVERHEAD LINE CATENARY, AND THE SURFACE OF THE GROUND WITHIN THE PIPELINE RIGHT-OF-WAY, OR THE PROJECTED LIMITS THEREOF WHERE IN A PUBLIC WAY, SHALL NOT BE LESS THAN THE MINIMUM VERTICAL CLEARANCE DISTANCE SET OUT IN THAT PART OF THE CANADIAN ELECTRICAL CODE PART III (CSA STANDARDS C22.3).

FOR CROSSINGS BELOW 50 kV, FIELD STAFF WILL PROVIDE T & D SUPPORT SERVICES DEPARTMENT, HEAD OFFICE WITH:

- DIMENSIONS IN METRES TO ONE DECIMAL.
- CROSSING IN RELATION TO NEAREST ROAD ALLOWANCE CENTRE LINE OR SECTION LINE.
- CROSSING NUMBER, IF EXISTING, LAND LOCATION, AND NORTH DIRECTIONAL SIGN.
- TIME AND DATE OF PROPOSED CONSTRUCTION.
- T & D SUPPORT SERVICES DEPARTMENT SHOULD HAVE INFORMATION 10 DAYS PRIOR TO CONSTRUCTION FOR NECESSARY PIPELINE APPROVALS.

H. P. TRANSMISSION PIPELINES

- AERIAL CABLE MARKERS ON NEW 25KV LINES SHALL BE INSTALLED ON SPANS CROSSING THE RIGHT OF WAY AS PER A-30-02.

*SaskPower* SUBSCRIPTION STANDARDS

DRN. <i>A</i>	DESIGN CHK.	APPROVAL	PIPELINES CROSSING SASKATCHEWAN BORDERS
CHKD.			
DATE	DATE	DATE	
DATE OF ISSUE	DRAWING NO. C-24-23.01	SHEET 1 of 2	REV. B

**II. OVERHEAD POWER LINES PROPOSED TO CROSS EXISTING PIPELINES WHICH ARE NOT UNDER THE JURISDICTION OF THE NATIONAL ENERGY BOARD**

FIELD OFFICE SHOULD MAKE DIRECT CONTACT WITH THE PIPELINE COMPANY(S) INVOLVED. THERE IS NO NEED FOR DRAWINGS OR APPLICATIONS TO BE SENT INTO HEAD OFFICE.

SPECIAL CONSTRUCTION REQUIREMENTS ARE:

- UNDER NO CIRCUMSTANCES CAN ANY SASKPOWER POLES, PYLONS, TOWERS, ANCHORS, GUYS, OR ANY FACILITIES BE PLACED WITHIN THE PIPELINE COMPANIES RIGHT-OF-WAY.
- NONE OF SASKPOWER'S FACILITIES SHOULD BE PLACED CLOSER THAN 5 METRES TO THE RIGHT-OF-WAY OR WITHIN 10 METRES OF THE PIPELINE.

H. P. TRANSMISSION PIPELINES

- AERIAL CABLE MARKERS ON NEW 25KV LINES SHALL BE INSTALLED ON SPANS CROSSING THE RIGHT-OF-WAY AS PER A-30-02.

**III. PIPELINES PROPOSED TO CROSS EXISTING OVERHEAD POWER LINES**

THE PIPELINE COMPANY MUST GET APPROVAL FOR THEIR CROSSING FROM SASKPOWER PRIOR TO CONSTRUCTION. THE APPLICATIONS SHOULD BE FORWARDED TO SUPPORT SERVICES, HEAD OFFICE. SASKPOWER COORDINATORS WILL MAKE ARRANGEMENTS FOR THE APPROVAL FOR THESE CROSSINGS.

SASKPOWER ASKS FOR 72 HOURS ADVANCE NOTICE PRIOR TO CONSTRUCTION SO A REPRESENTATIVE CAN BE ON SITE AT THE TIME OF CONSTRUCTION. THE APPLICANT SHOULD HAVE A DETAILED LIST OF LOCATIONS FOR CROSSING UNDER POWER LINES. SASKPOWER WILL PREPARE AN ESTIMATE OF THE ADDITION AND/OR RELOCATION OF THEIR FACILITIES BY THE PIPELINE CROSSING.

H. P. TRANSMISSION PIPELINES

- AERIAL CABLE MARKERS ON THE EXISTING 25KV LINE SHALL BE INSTALLED ON SPANS CROSSING THE RIGHT-OF-WAY AS PER A-30-02 IF REQUESTED BY THE PIPELINE COMPANY. THE AERIAL MARKER SHALL BE INSTALLED AT THE PIPELINE COMPANY'S EXPENSE.

**IV. OVERHEAD POWER LINES PROPOSED WITHIN PROXIMITY TO TRANSGAS PIPELINES**

CORPORATE CONSENT IS REQUIRED WHEN WORKING WITHIN 10 METRES OF A TRANSGAS EASEMENT. IF NO EASEMENT EXISTS, THEN CONSENT IS REQUIRED WITHIN 15 METRES OF A TRANSGAS PIPELINE.

A PROXIMITY AGREEMENT IS REQUIRED FOR ANY WORK WITHIN 30 METRES OF A TRANSGAS PIPELINE.

A CROSSING PERMIT IS REQUIRED FOR ALL NEW CONSTRUCTION AND SALVAGE WORK, EVEN IF JUST DRIVING OVER THE PIPELINE RIGHT-OF-WAY. A CROSSING PERMIT IS NOT REQUIRED IF USING AN EXISTING PUBLIC ROADWAY TO DRIVE OVER THE RIGHT-OF-WAY.

**SaskPower - DISTRIBUTION STANDARDS**

APPROVAL <b>L. MOEN</b>	DESIGN CHK <b>A. UHREN</b>	DRN. <b>ARU</b>	<b>PIPELINES CROSSING SASKATCHEWAN BORDERS</b>
		CHKD.	
		<b>2017-01-16</b>	
DATE OF ISSUE: 2017/05/03		DRAWING NO: <b>C-24-23.01</b>	<b>SHEET 2 of 2</b>   REV. <b>C</b>

"OVERHEAD PIPELINE CROSSINGS"  
"APPLICATION REQUIREMENTS FROM FIELD STAFF"

- (1) Show all dimensions in METRES to ONE DECIMAL.
- (2) Indicate SUBPROJECT NUMBER.
- (3) Locate CROSSING in relation to nearest ROAD ALLOWANCE CENTRE LINE or SECTION LINE.
- (4) See that CROSSING NUMBER, LOCATION, and NORTH SIGN are correct.
- (5) Indicate all POLES and ANCHORS on PIPELINE PROPERTY.
- (6) Indicate VOLTAGE and CONDUCTOR SIZE.
- (7) Attach STAKING SHEET to FIELD CHECK SHEET.
- (8) FIELD CHECK SHEETS to be submitted at EARLIEST possible time to CONTRACT ADMINISTRATION DEPARTMENT, HEAD OFFICE. Request will take approximatly 6 weeks to PROCESS with NATIONAL ENERGY BOARD.
- (9) – TIME and DATE OF CONSTRUCTION.

SASKATCHEWAN POWER CORP. – DISTRIBUTION ENGINEERING STANDARDS					
DRN. <i>A</i>	DESIGN CHK.	SAFETY APP.	APPROVAL	APPLICATION REQUIREMENTS	
CHKD. <i>FTK</i>					
DATE 87-04-22	DATE	DATE	DATE		
DATE OF ISSUE	87-06-01	DRAWING NO.	C-24-23.02	SHEET 1 of 2	REV. 0

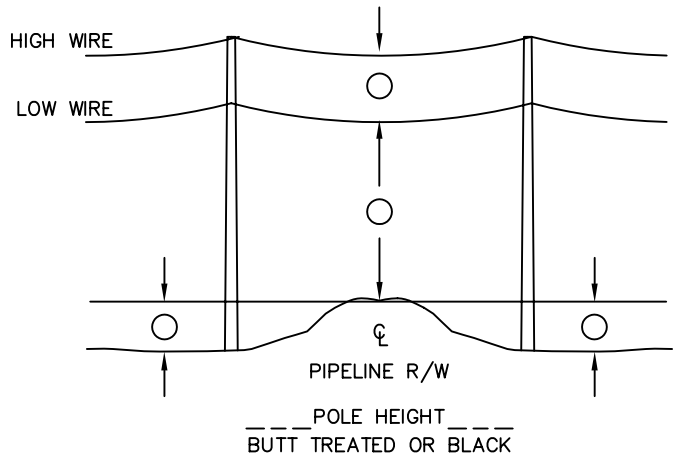
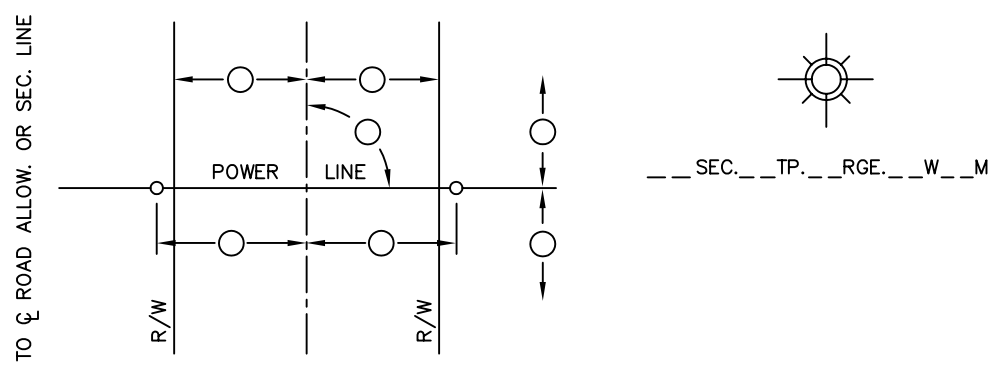
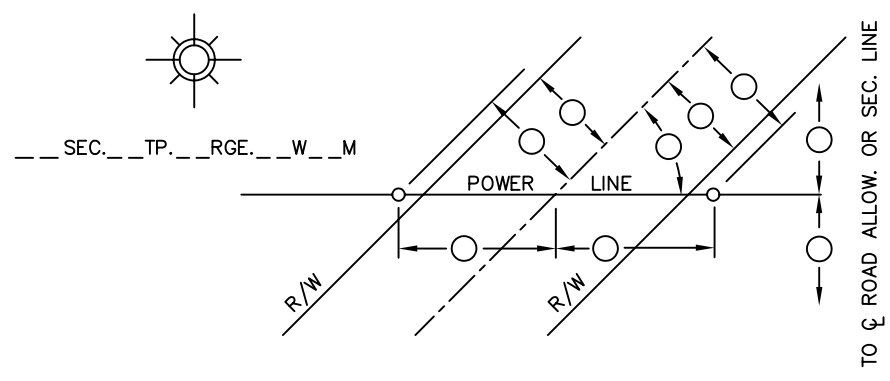
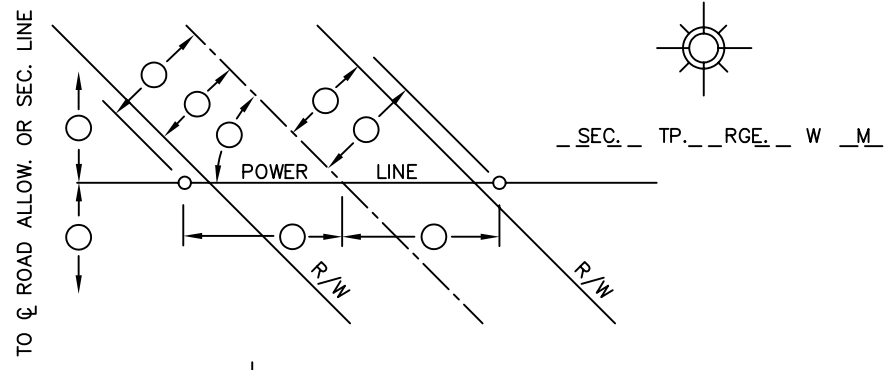

DATE OF CONSTRUCTION \_\_\_\_\_  
 LOCATION \_\_\_\_\_  
 CONDUCTORS \_\_\_\_\_  
 INSULATORS \_\_\_\_\_  
 VOLTAGE \_\_\_\_\_

PLC \_\_\_\_\_

1. LOCATE CROSSING IN RELATION TO NEAREST ROAD ALLOW. OR SEC. LINE.
2. INDICATE STRUCTURE OR DRAWING NUMBER.
3. SEE THAT CROSSING NUMBER, LOCATION AND NORTH SIGN ARE CORRECT.
4. INDICATE ALL POLES AND ANCHORS ON PIPELINE PROPERTY.

SASKATCHEWAN POWER CORP. – DISTRIBUTION ENGINEERING STANDARDS

DRN. <i>R</i>	DESIGN CHK.	SAFETY APP.	APPROVAL	APPLICATION REQUIREMENTS
CHKD. <i>FTK</i>				
DATE 87-04-22	DATE	DATE	DATE	
DATE OF ISSUE 87-06-01	DRAWING NO. C-24-23.02		SHEET 2 of 2	REV. 0